



Main

Range of product	Modicon STB distributed I/O solution
Product or component type	Standard analog input kit
Kit composition	STBXTS1100, 6-terminal screw type connector STBXTS2100, 6-terminal spring clamp connector STBACI1400 module STBXBA2000 base
Analogue input type	Current 0...20 mA Current 4...20 mA
Analogue input number	8
Analogue input resolution	15 bits + sign
Type of filter	Single low pass input filter 985 Hz

Complementary

Absolute maximum input	25 mA/50 V DC
Cold swapping	Yes
Hot swapping fallback	Yes for standard NIMs
Fallback status	State 0 basic NIMs User configurable standard NIMs
Data format	EN 61131-2 IEC 61131-2
Update time	22 ms
Integral linearity	+/- 0.08 %FS
Differential linearity	Monotonic
Input impedance	<= 250 Ohm
Maximum supply current for sensors	100 mA per input channels
Absolute accuracy error	+/- 0.4 % of full scale per °C
Temperature drift	+/-0.005 %/°C

Disclaimer: This documentation is not intended as a substitute for and is not to be used for determining suitability or reliability of these products for specific user applications

Insulation between channels and logic bus	1500 V for 1 minute
Insulation between channels and sensor bus	30 V
Addressing requirement	16 input words
Product compatibility	Power distribution module STBPDT3100/3105 Mounting base STBXBA2000
[Us] rated supply voltage	24 V DC
Supply	Power distribution module
Current consumption	90 mA at 5 V DC for logic bus
Marking	CE
Overvoltage category	II
Status LED	1 LED (green) module status (RDY)
Depth	70 mm
Height	18.4 mm
Width	128.3 mm

Environment

Product certifications	FM Class 1 Division 2 CSA UL ATEX Cat 3G C-Tick
Pollution degree	2 conforming to IEC 60664-1
Operating altitude	<= 2000 m
IP degree of protection	IP20 conforming to EN 61131-2 class 1
Ambient air temperature for operation	-25...70 °C
Ambient air temperature for operation	- 13...158 °F
Ambient air temperature for storage	-40...85 °C without derating
Ambient air temperature for storage	-40...185 °F without derating
Relative humidity	95 % at 60 °C without condensation
Vibration resistance	+/-0.35 mm at 10...58 Hz 3 gn at 58...150 Hz on 35 x 7.5 mm symmetrical DIN rail 5 gn at 58...150 Hz on 35 x 15 mm symmetrical DIN rail
Shock resistance	30 gn for 11 ms conforming to IEC 88 reference 2-27

Packing Units

Unit Type of Package 1	PCE
Number of Units in Package 1	1
Package 1 Weight	147 g
Package 1 Height	2.5 cm
Package 1 width	8 cm
Package 1 Length	13 cm
Unit Type of Package 2	S02
Number of Units in Package 2	28
Package 2 Weight	4.542 kg
Package 2 Height	15 cm
Package 2 width	30 cm
Package 2 Length	40 cm

Offer Sustainability

Sustainable offer status	Green Premium product
REACH Regulation	REACH Declaration
EU RoHS Directive	Pro-active compliance (Product out of EU RoHS legal scope) EU RoHS Declaration

Mercury free	Yes
RoHS exemption information	Yes
China RoHS Regulation	China RoHS declaration
Environmental Disclosure	Product Environmental Profile
Circularity Profile	End of Life Information
WEEE	The product must be disposed on European Union markets following specific waste collection and never end up in rubbish bins

Contractual warranty

Warranty	18 months
----------	-----------

Dimensions

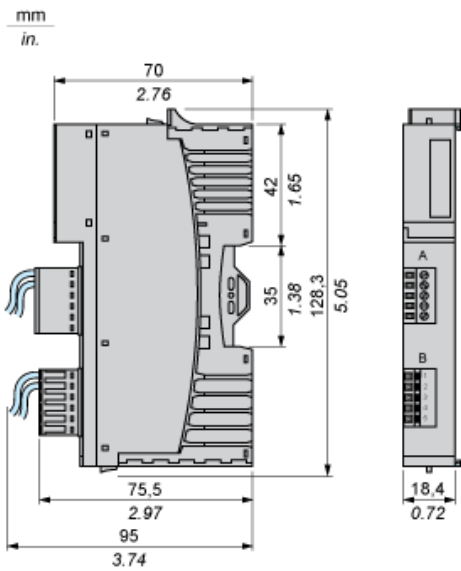

Wiring Diagram

Example

8 isolated analog sensors, external 24 VDC power supply

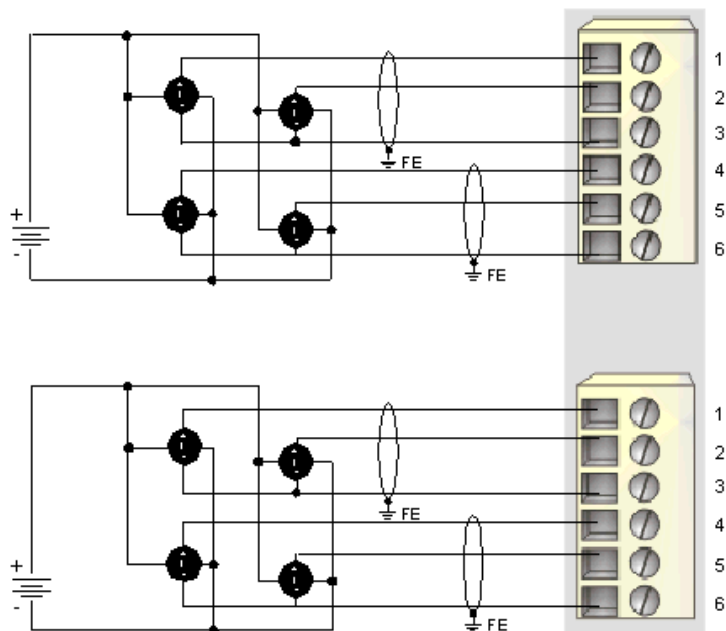

Pin	Top Connections	Bottom Connections
1	current in 1	current in 5
2	current in 2	current in 6
3	return	return
4	current in 3	current in 7
5	current in 4	current in 8
6	return	return