



### Main

Range of product	Modicon STB distributed I/O solution
Product or component type	Standard digital input kit
Kit composition	STBXTS2100, 6-terminal spring clamp connector STBDDI3420 module STBXTS1100, 6-terminal screw type connector STBXBA1000 base
Discrete input number	4
Discrete input voltage	24 V
Discrete input voltage type	DC

### Complementary

Input voltage limits	11...30 V at state 1 -3...5 V at state 0
Permissible voltage	30 V
Absolute maximum voltage	56 V 1.3 ms
Discrete input current	8 mA
Current state 0 guaranteed	<= 1.2 mA
Current state 1 guaranteed	>= 2.5 mA
Discrete input logic	Positive or negative
Response time	0.925 ms off-to-on 0.5 ms 1.35 ms on-to-off 0.5 ms
Protection type	Power protection integrated fuse on PDM time lag 10 A Input protection resistor-limited Reverse polarity protection
Insulation between channels and logic bus	1500 V for 1 minute
Cold swapping	Yes
Hot swapping	Yes for standard NIMs
Input filtering	1 ms 2 ms 4 ms

Disclaimer: This documentation is not intended as a substitute for and is not to be used for determining suitability or reliability of these products for specific user applications

	8 ms 0.5 ms 16 ms +/- 0.25 ms
Current supplied by sensor	100 mA per channel
Product compatibility	I/O base STBXBA1000 Power distribution module STBPDT3100/3105
[Us] rated supply voltage	24 V DC
Supply	Power distribution module
Current consumption	45 mA at 5 V DC for logic bus
Marking	CE
Overvoltage category	II
Status LED	1 LED (green)module status (RDY) 1 LED per channel (green)channel status (IN1 to IN4) 1 LED (red)module error (ERR)
Depth	65.1 mm
Height	18.4 mm
Width	125 mm
Net weight	0.111 kg

## Environment

Standards	EN/IEC 61131-2type 1+
Product certifications	CSA FM Class 1 Division 2 UL
Pollution degree	2 conforming to IEC 60664-1
Operating altitude	<= 2000 m
IP degree of protection	IP20 conforming to EN 61131-2 class 1
Ambient air temperature for operation	-25...70 °C (without derating)
Ambient air temperature for operation	32...140 °F without derating
Ambient air temperature for storage	-40...85 °C without derating
Ambient air temperature for storage	-40...185 °F without derating
Relative humidity	95 % at 60 °C without condensation
Vibration resistance	3 gn at 58...150 Hz on 35 x 7.5 mm symmetrical DIN rail 5 gn at 58...150 Hz on 35 x 15 mm symmetrical DIN rail +/-0.35 mm at 10...58 Hz
Shock resistance	30 gn for 11 ms conforming to IEC 88 reference 2-27

## Packing Units

Package 1 Weight	0.131 kg
Package 1 Height	25.000 mm
Package 1 width	80.000 mm
Package 1 Length	130.000 mm

## Offer Sustainability

Sustainable offer status	Green Premium product
REACH Regulation	<a href="#">REACH Declaration</a>
EU RoHS Directive	Pro-active compliance (Product out of EU RoHS legal scope) <a href="#">EU RoHS Declaration</a>
Mercury free	Yes
RoHS exemption information	<a href="#">Yes</a>
China RoHS Regulation	<a href="#">China RoHS declaration</a>
Environmental Disclosure	<a href="#">Product Environmental Profile</a>
Circularity Profile	<a href="#">End of Life Information</a>
WEEE	The product must be disposed on European Union markets following specific waste collection and never end up in rubbish bins

## Contractual warranty

---

Warranty	18 months
----------	-----------

---

Dimensions

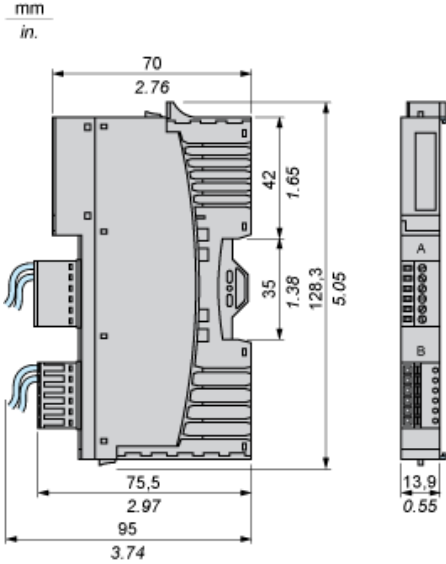

## Wiring Diagram

### Example

2 three-wire sensor and 2 two-wire sensor

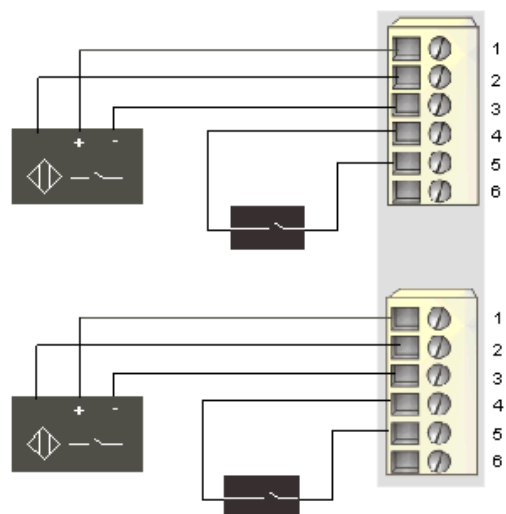

Pin	Top Connector	Bottom Connector
1	+24 VDC from sensor bus for field device accessories	+24 VDC from sensor bus for field device accessories
2	input from sensor 1	input from sensor 3
3	field power return (to the module)	field power return (to the module)
4	+24 VDC from sensor bus for field device accessories	+24 VDC from sensor bus for field device accessories
5	input from sensor 2	input from sensor 4
6	field power return (to the module)	field power return (to the module)