



ⓘ Discontinued

Main

Range of product	Altivar 32
Product or component type	Variable speed drive
Product destination	Asynchronous motors Synchronous motors
Product specific application	Complex machines
Function available	-
Assembly style	With heat sink
Component name	ATV32
EMC filter	Class C2 EMC filter integrated
Network number of phases	3 phases
[Us] rated supply voltage	380...500 V - 15...10 %
Supply voltage limits	323...550 V
Supply frequency	50...60 Hz - 5...5 %
Network frequency	47.5...63 Hz
Motor power kW	4 kW at 380...480 V
Motor power hp	5 hp at 380...480 V

Complementary

Line current	10.5 A for 500 V 3 phases 4 kW / 5 hp 13.7 A for 380 V 3 phases 4 kW / 5 hp
Apparent power	9.1 kVA at 500 V 3 phases 4 kW / 5 hp
Prospective line I _{sc}	5 kA for 3 phases
Nominal output current	9.5 A at 4 kHz 500 V 4 kW / 5 hp
Maximum transient current	14.3 A for 60 s 4 kW / 5 hp
Output frequency	0.0005...0.599 kHz
Nominal switching frequency	4 kHz
Switching frequency	2...16 kHz adjustable
Speed range	1...100 for asynchronous motor in open-loop mode
Speed accuracy	+/- 10 % of nominal slip 0.2 T _n to T _n
Torque accuracy	+/- 15 %
Transient overtorque	170...200 %
Braking torque	<= 170 % with braking resistor

Asynchronous motor control profile	Voltage/frequency ratio - Energy Saving, quadratic U/f Flux vector control without sensor, standard Voltage/frequency ratio, 5 points Flux vector control without sensor - Energy Saving, NoLoad law Voltage/frequency ratio, 2 points
Synchronous motor control profile	Vector control without sensor
Regulation loop	Adjustable PID regulator
Motor slip compensation	Adjustable 0...300 % Automatic whatever the load Not available in voltage/frequency ratio (2 or 5 points)
Local signalling	1 LED red for drive voltage 1 LED green for CANopen run 1 LED red for CANopen error 1 LED red for drive fault
Output voltage	<= power supply voltage
Noise level	45 dB conforming to 86/188/EEC
Insulation	Electrical between power and control
Electrical connection	Screw terminal, clamping capacity: 0.5...1.5 mm ² , AWG 18...AWG 14 (control) Removable screw terminals, clamping capacity: 1.5...2.5 mm ² , AWG 14...AWG 12 (motor/braking resistor) Screw terminal, clamping capacity: 2.5...4 mm ² , AWG 12...AWG 10 (power supply)
Tightening torque	0.5 N.m, 4.4 lb/ft (control) 0.7 N.m, 7.1 lb/ft (motor/braking resistor) 0.6 N.m, 5.3 lb/ft (power supply)
Supply	Internal supply for reference potentiometer (1 to 10 kOhm): 10.5 V DC +/- 5 %, <10 mA, protection type: overload and short-circuit protection
Analogue input number	3
Analogue input type	AI1 voltage: 0...10 V DC, impedance: 30000 Ohm, resolution 10 bits AI2 bipolar differential voltage: +/- 10 V DC, impedance: 30000 Ohm, resolution 10 bits AI3 current: 0...20 mA (or 4-20 mA, x-20 mA, 20-x mA or other patterns by configuration), impedance: 250 Ohm, resolution 10 bits
Sampling duration	2 ms (AI1, AI2, AI3) - analog input(s) 2 ms (AO1) - analog input(s)
Response time	LI1...LI6 8 ms, tolerance +/- 0.7 ms for logic output(s) R1A, R1B, R1C 2 ms for relay output(s) R2A, R2C 2 ms for relay output(s)
Accuracy	+/- 0.2 % (AI1, AI2, AI3) for a temperature of -10...60 °C +/- 0.5 % (AI1, AI2, AI3) for a temperature of 25 °C +/- 1 % (AO1) for a temperature of 25 °C +/- 2 % (AO1) for a temperature of -10...60 °C
Linearity error	+/- 0.2...0.5 % of maximum value (AI1, AI2, AI3) +/- 0.3 % (AO1)
Analogue output number	1
Analogue output type	AO1 software-configurable current 0...20 mA, impedance: 800 Ohm, resolution 10 bits AO1 software-configurable voltage 0...10 V, impedance: 470 Ohm, resolution 10 bits
Discrete output number	3
Discrete output type	Configurable relay logic: (R1A, R1B, R1C) NO/NC - 100000 cycles Configurable relay logic: (R2A, R2B) NO - 100000 cycles Logic: (LO)
Minimum switching current	5 mA at 24 V DC for configurable relay logic
Maximum switching current	R1: 3 A at 250 V AC resistive load, cos phi = 1 R1: 4 A at 30 V DC resistive load, cos phi = 1 R1, R2: 2 A at 250 V AC inductive load, cos phi = 0.4 R1, R2: 2 A at 30 V DC inductive load, cos phi = 0.4 R2: 5 A at 250 V AC resistive load, cos phi = 1 R2: 5 A at 30 V DC resistive load, cos phi = 1
Discrete input number	7
Discrete input type	Programmable (sink/source) (LI1...LI4)24...30 V DC, with level 1 PLC Programmable as pulse input 20 kpps (LI5)24...30 V DC, with level 1 PLC Switch-configurable PTC probe (LI6)24...30 V DC Safe torque off (STO)24...30 V DC - 1500 Ohm
Discrete input logic	Negative logic (sink) (LI1...LI6), > 19 V (state 0), < 13 V (state 1) Positive logic (source) (LI1...LI6), < 5 V (state 0), > 11 V (state 1)
Acceleration and deceleration ramps	U

	CUS Deceleration ramp adaptation Linear S Ramp switching Deceleration ramp automatic stop DC injection
Braking to standstill	By DC injection
Protection type	Input phase breaks: drive Overcurrent between output phases and earth: drive Overheating protection: drive Short-circuit between motor phases: drive Thermal protection: drive
Communication port protocol	Modbus CANopen
Connector type	1 RJ45 (on front face) for Modbus/CANopen
Physical interface	2-wire RS 485 for Modbus
Transmission frame	RTU for Modbus
Type of polarization	No impedance for Modbus
Number of addresses	1...127 for CANopen 1...247 for Modbus
Method of access	Slave CANopen
Electromagnetic compatibility	1.2/50 μ s - 8/20 μ s surge immunity test, level 3 conforming to IEC 61000-4-5 Conducted radio-frequency immunity test, level 3 conforming to IEC 61000-4-6 Electrical fast transient/burst immunity test, level 4 conforming to IEC 61000-4-4 Electrostatic discharge immunity test, level 3 conforming to IEC 61000-4-2 Radiated radio-frequency electromagnetic field immunity test, level 3 conforming to IEC 61000-4-3 Voltage dips and interruptions immunity test conforming to IEC 61000-4-11
Width	60 mm
Height	325 mm
Depth	245 mm
Product weight	3 kg
Option card	Communication card for CANopen daisy chain Communication card for CANopen open style Communication card for DeviceNet Communication card for Ethernet/IP Communication card for Profibus DP V1
Functionality	Mid
Specific application	Other applications

Environment

Standards	EN/IEC 61800-3 EN 61800-3 environments 2 category C2 EN 61800-3 environments 1 category C2 EN 55011 class A group 1 EN/IEC 61800-5-1
Product certifications	NOM 117 C-Tick GOST UL CSA
Marking	CE
Pollution degree	2 conforming to EN/IEC 61800-5-1
IP degree of protection	IP20 conforming to EN/IEC 61800-5-1
Vibration resistance	1 gn (f = 13...200 Hz) conforming to EN/IEC 60068-2-6 1.5 mm peak to peak (f = 3...13 Hz) conforming to EN/IEC 60068-2-6
Shock resistance	15 gn for 11 ms conforming to EN/IEC 60068-2-27
Relative humidity	5...95 % without condensation conforming to IEC 60068-2-3 5...95 % without dripping water conforming to IEC 60068-2-3
Ambient air temperature for operation	-10...50 °C without 50...60 °C with derating factor
Ambient air temperature for storage	-25...70 °C
Operating altitude	<= 1000 m without

1000...3000 m with current derating 1 % per 100 m

Operating position

Vertical +/- 10 degree

Contractual warranty

Warranty

18 months

Size B

Dimensions

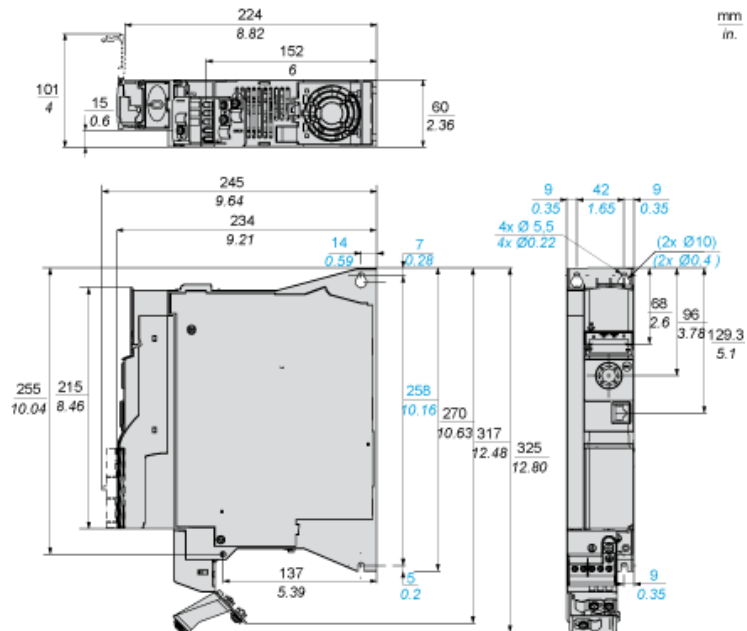

Mounting and Clearance

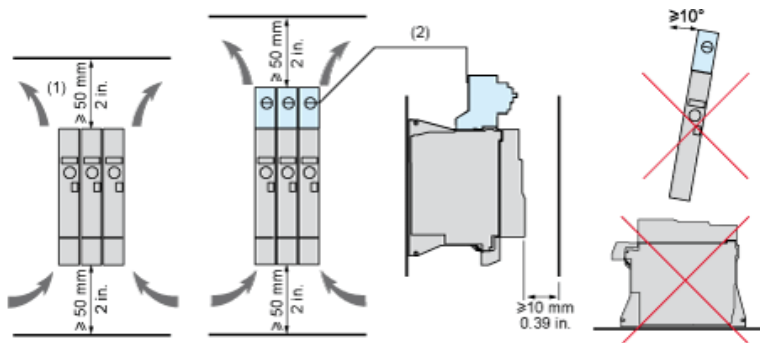

- (1) Minimum value corresponding to thermal constraints. A 150 mm clearance may help to connect the ground.
- (2) Optional GV2 circuit-breaker

Option: Protection Device, GV2 circuit-breaker

The drive is prepared to be equipped with an optional GV2 circuit-breaker.

The GV2 circuit-breaker is directly mounted on the drive. Mechanical and electrical link are made using the optional adapter. The options are supplied with detailed mounting instruction sheet.

NOTE: The product overall dimension, including GV2 adapter and EMC plate mounted, becomes 424 mm (16.7 in.)

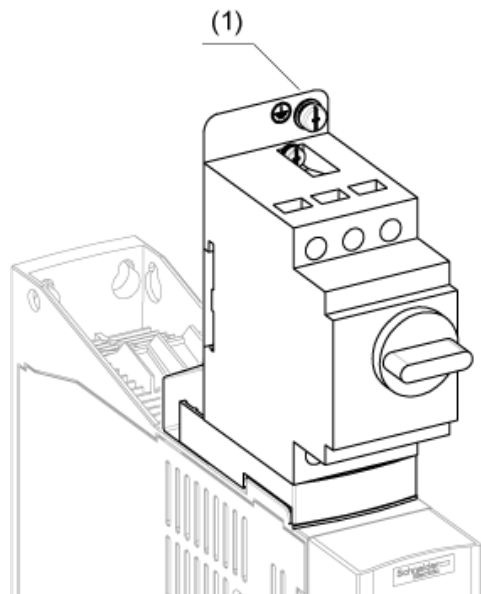

(1) Ground screw (HS type 2 - 5x12)

Connection Diagrams

Single or Three-phase Power Supply - Diagram with Line Contactor

Connection diagrams conforming to standards EN 954-1 category 1 and IEC/EN 61508 capacity SIL1, stopping category 0 in accordance with standard IEC/EN 60204-1.

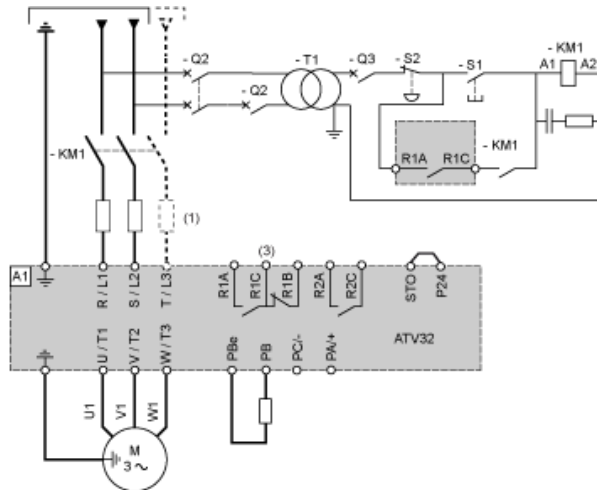

- (1) Line choke (if used)
- (3) Fault relay contacts, for remote signaling of drive status

Single or Three-phase Power Supply - Diagram with Switch Disconnect

Connection diagrams conforming to standards EN 954-1 category 1 and IEC/EN 61508 capacity SIL1, stopping category 0 in accordance with standard IEC/EN 60204-1.

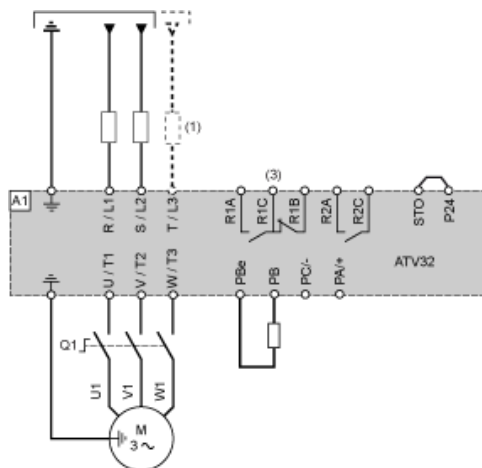

- (1) Line choke (if used)
- (3) Fault relay contacts, for remote signaling of drive status

Diagram with Preventa Safety Module (Safe Torque Off Function)

Connection diagrams conforming to standards EN 954-1 category 3 and IEC/EN 61508 capacity SIL2, stopping category 0 in accordance with standard IEC/EN 60204-1.

When the emergency stop is activated, the drive power supply is cut immediately and the motor stops in freewheel, according to category 0 of standard IEC/EN 60204-1.

A contact on the Preventa XPS AC module must be inserted in the brake control circuit to engage it safely when the STO (Safe Torque Off) safety function is activated.

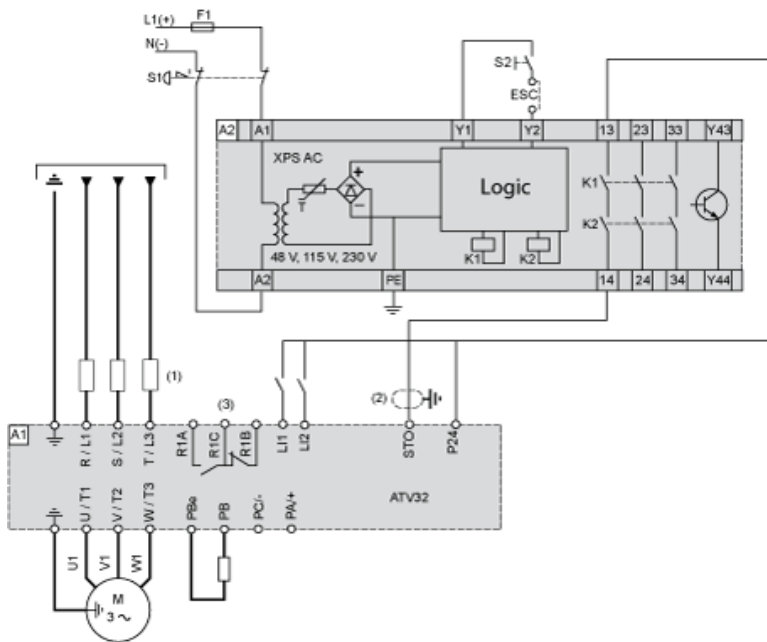

- (1) Line choke (if used)
- (2) It is essential to connect the shielding to the ground.
- (3) Fault relay contacts, for remote signaling of drive status

The STO safety function integrated into the product can be used to implement an "EMERGENCY STOP" (IEC 60204-1) for category 0 stops. With an additional, approved EMERGENCY STOP module, it is also possible to implement category 1 stops.

STO function

The STO safety function is triggered via 2 redundant inputs. The circuits of the two inputs must be separate so that there are always two channels. The switching process must be simultaneous for both inputs (offset < 1 s).

The power stage is disabled and an error message is generated. The motor can no longer generate torque and coasts down without braking. A restart is possible after resetting the error message with a "Fault Reset".

The power stage is disabled and an error message is generated if only one of the two inputs is switched off or if the time offset is too great. This error message can only be reset by switching off the product.

Diagram without Preventa Safety Module

Connection diagrams conforming to standards EN 954-1 category 2 and IEC/EN 61508 capacity SIL1, stopping category 0 in accordance with standard IEC/EN 60204-1.

The connection diagram below is suitable for use with machines with a short freewheel stop time (machines with low inertia or high resistive torque).

When the emergency stop is activated, the drive power supply is cut immediately and the motor stops in freewheel, according to category 0 of standard IEC/EN 60204-1.

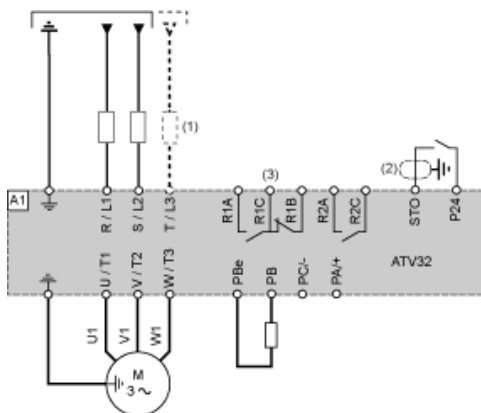

- (1) Line choke (if used)
- (2) It is essential to connect the shielding to the ground.
- (3) Fault relay contacts, for remote signaling of drive status

The STO safety function integrated into the product can be used to implement an "EMERGENCY STOP" (IEC 60204-1) for category 0 stops.

Derating Curves

Derating curve for the nominal drive current (I_n) as a function of temperature and switching frequency.

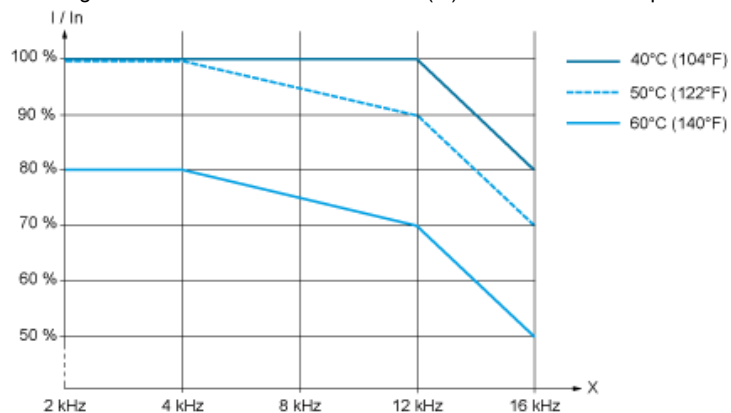

X Switching frequency

Above 4 kHz, the drive will reduce the switching frequency automatically in the event of an excessive temperature rise.

Sink / Source Switch Configuration (SW1)

The logic input switch (SW1) is used to adapt the operation of the logic inputs to the technology of the programmable controller outputs.
 Switch SW1 set to "Source" position

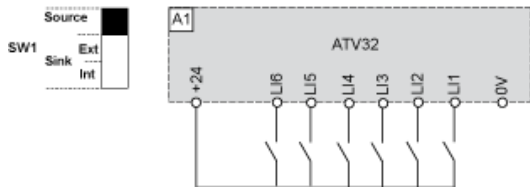

Switch SW1 set to "Source" position and use of an external power supply for the LIs

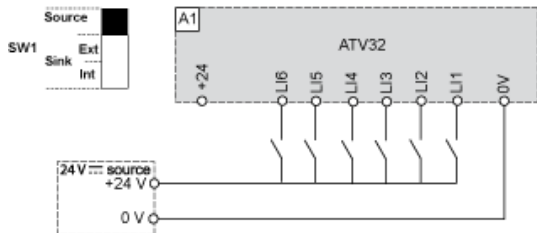

Switch SW1 set to "Sink Int" position

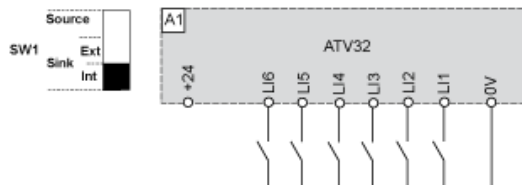

Switch SW1 set to "Sink Ext" position

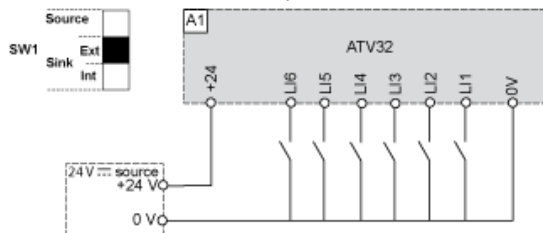

ATV32HU40N4 is replaced by:



Variable speed drives ATV320U40N4B

variable speed drive, ATV320, 4 kW, 380...500 V, 3 phases, book

Qty 1

Reason for Substitution: End of life | Substitution date: 03 May 2016